



T35120SL | Telescopic Handlers



Performance

Lifting height — on stabilisers	11850.0 mm
Lifting height — on tyres	11530.0 mm
Rated capacity	3500 kg
Capacity (at max. height on stabilisers)	3200 kg
Capacity (at max. height on tyres)	2300 kg
Capacity (at max. reach on stabilisers)	1200 kg
Capacity (at max. reach on tyres)	350 kg
Max. reach on stabilisers	8120.0 mm
Max. reach on tyres	8190.0 mm
Crowding force	4600 daN

Weights

Weight (unladen)	8240 kg
------------------	---------

Traction

Standard tyres	TITAN 400/70x20 150B 166A2 LIFT RIGGER II (4 bar front/rear)
Low speed (forward/reverse)	7.0 km/h
High speed (forward/reverse)	30.0 km/h
Driving modes	Direct drive / soft drive

Drive System

Main drive	2-speed hydrostatic motor
Transmission	Hydrostatic with electronic regulation

Engine

Make/Model	PERKINS / 1104D-44TA turbo
Fuel	Diesel
Cooling	Liquid
Rated power (DIN 6271) at 2200 RPM	74.5 kW
Maximum torque at 1400 RPM	410.0 Nm
Number of cylinders	4
Displacement	4.40 L

Hydraulic System

Pump type	Gear pump with LS valve
Combined pump capacity	135.00 L/min
Working pressure	265.00 bar

Cycle Times

Lift time - no load	10.0 s
Lower time - no load	5.5 s
Telescope in time at max. reach - no load	11.5 s
Telescope in time at max. height - no load	11.5 s
Telescope out time at max. reach - no load	13.0 s
Telescope out time at max. height - no load	13.0 s

Brakes

Engine braking	Hydrostatic
Parking and emergency brake	Negative brake with hydraulic command

Fluid Capacities

Axles and reduction gears front / rear	9.0/8.1 L
Engine oil	8.50 L
Fuel tank	140.00 L
Hydraulic reservoir	77.00 L

Standard Features

Aggravating Movements Arrester (AMA)	Right and left side mirrors
Hydrostatic transmission	Two way hydraulic supply at the end of the boom
ROPS/FOPS operator cab	Mudguards
Heating, demisting and ventilation	Turbo-charged engine
Front and rear washer/wipers	Narrow hook-up for mounting of the equipment
Suspension seat	Mechanical lock of the equipment
Road lights	Four TITAN 400/70x20 150B 166A2 Lift Rigger II tyres
Turn signals	

Options

Back up alarm	Work light on boom
Second hydraulic function on boom	Set of blue lights for hen houses
Air conditioning	Carriage with hydraulic attachment lock
Rear hydraulic hook and mirror	Yoke and electrical plug

Load Charts

With forks and TITAN 400/70 x 20 150B 166A2 LIFT RIGGER II tyres

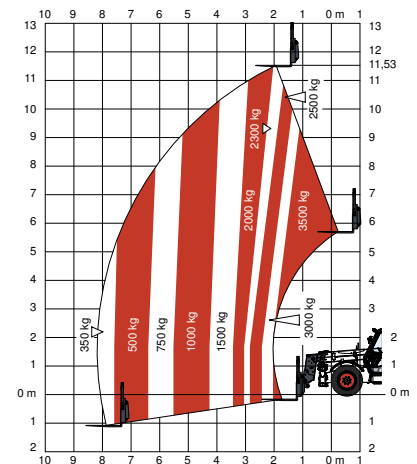

Complies with stability test EN1459 Annex B.

Dimensions

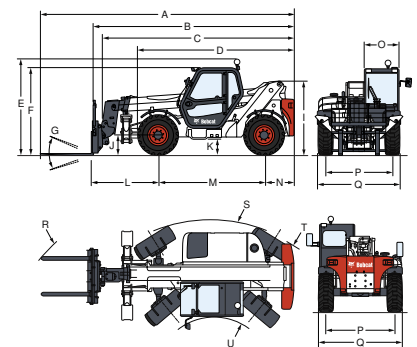

(-)	1600.0 mm	(I)	2079.0 mm
(-)	920.0 mm	(J)	419.0 mm
(-)	1165.0 mm	(M)	2850.0 mm
(-)	4360.0 mm	(N)	800.0 mm
(-)	120.0 mm	(O)	930.0 mm
(-)	2475.0 mm	(P)	1812.0 mm
(A)	6789.0 mm	(Q)	2216.0 mm
(B)	5584.0 mm	(R)	5400.0 mm
(C)	5461.0 mm	(R)	5350.0 mm
(D)	3775.0 mm	(R)	5450.0 mm
(E)	2610.0 mm	(S)	3900.0 mm
(F)	2295.0 mm	(T)	4000.0 mm
(G)	145°	(U)	1370.0 mm



www.bobcat.eu